

# Storci

PASTA MACHINERY

# STE 1120-1500 SPREADING MACHINE

AUTOMATIC SPREADING MACHINES FOR LONG-CUT PASTA



rev. 0043.2306.53

■ Automatic spreading machine, model STE 1120

- Automatic spreading machines for long-cut pasta with 1120 and 1500 mm sticks
- Standard pasta types (*spaghetti, tagliatelle*, etc.)
- Automatic system for collecting and grinding pasta scraps
- Automatic stick pick-up and regulation of the pasta cutting length

we know pasta

# STE 1120-1500 SPREADING MACHINE

Spreading machines suitable for long-cut pasta lines to be coupled to linear and circular heads (\*). PLC control. The new design, the use of new materials, the technical solutions adopted and the particularly sturdy framework have made it possible to construct easy-to-clean and low-maintenance machines.

## Main technical features:

- Empty stick accumulation guides with manual feed
- Automatic pick-up of the sticks by means of chains with loops
- Upper ventilation ring for surface drying the pasta
- Arms with chains for automatic feeding of the long-cut pasta pre-drying tunnel
- Sickle bar trimmer
- Long cut of the pasta: 580 mm
- Pneumatic conveyor system for taking pasta scraps to the press kneader, complete with fan-grinder, stainless steel transport piping, decantation cyclone and vacuum seal valve
- Painted steel structure
- Short-cut pasta conveyor belt and tray passage system for special Omnia lines.

(\* ) with spreading cone for circular head



Application of STE 1120 on double-head Omnia line



Application of STE 1120 on Omnia line with "mushroom head" spreading machine



Application of spreading machine STE 1120 on Omnia line with "mushroom head" spreader



Application of spreading machine STE 1120 on Omnia line

# STE 1120-1500 SPREADING MACHINE

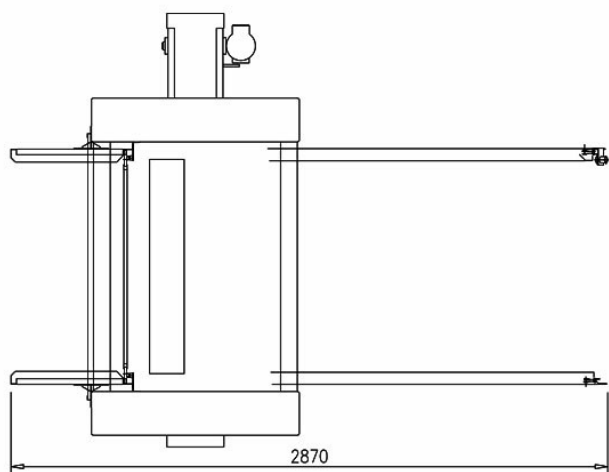
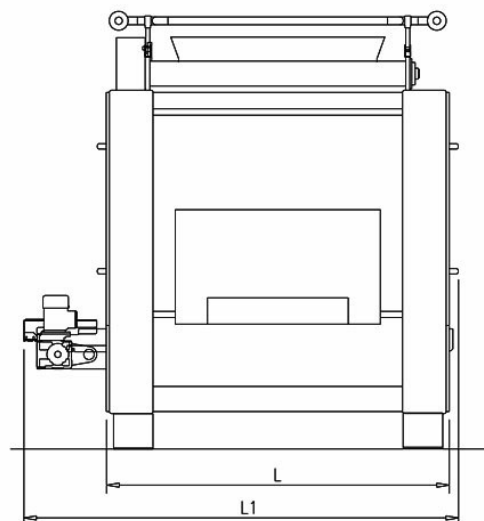
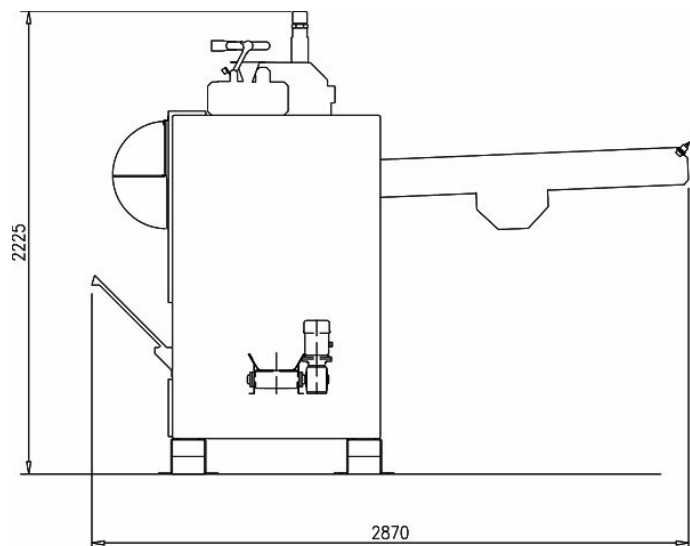

STE 1120-1500		
	STE 1120	STE 1500
Nominal stick length (mm)	1120	1500
Dry production (kg/h) for standard pasta types	400	500
Tray passage system	yes	yes
Cutting length (mm)	580	580
Power installed (kW)	8	8
Size (mm)	2090x2870x2225	2470x2870x2225

STE 1120-1500		
PASTA TYPES	STE 1120	STE 1500
Standard long-cut (e.g. spaghetti) Ø max. 1.7 mm	•	•
Bucati (Tubular pasta) (e.g. bucatini) Ø max. 3.5 mm	•	•
Tagliatelle: max. width 6 mm	•	•
Bucati speciali (special tubular pasta) (candele, ziti, etc.)		
American lasagna		
Fusilli bucati lunghi (long hollow fusilli)		

Notes: the data provided is purely indicative and not binding as it may be subject to the variability of products and the line in which units are installed



[facebook.com/storci.spa](https://facebook.com/storci.spa)



[youtube.com/user/StorciPastaMachinery](https://youtube.com/user/StorciPastaMachinery)



[linkedin.com/company/storci-spa](https://linkedin.com/company/storci-spa)

**Storci S.p.A.**  
via Lemignano, 6 - 43044 Collecchio (Parma)  
phone: +39 0521 543611 fax: +39 0521 543621  
[www.storci.com](http://www.storci.com) - [sales-storci@storci.com](mailto:sales-storci@storci.com)

